

## **Stainless Steel Slide and Weir Gates Suggested Specifications**

The slide and weir gates were shown in the plans and specifications shall be as manufactured by **Northcoast Valve and Gate, Inc.**

### **Materials and Construction**

Frame, Slide and Reinforcing Members - Stainless Steel, ASTM A276 Type 304 or 316

Stems - Stainless Steel, ASTM A276 Type 304 or 316

Fasteners - Stainless Steel, ASTM F593 Type 304 or 316

Rubber Seals - Neoprene, ASTM D2000

Guide Bars - Ultra High Molecular Weight Polyethylene, ASTM D4020

### **Guides**

Guides shall be of stainless steel type 304 or 316 with formed channel members for maximum rigidity. and shall be of either face mounted or embedded design as shown on the plans.

### **Disc**

Disc shall be constructed of stainless steel type 304 or 316 with 1/4" minimum thickness and reinforced with structural members to limit deflection to 1/360 of span under full head conditions.

### **Seals**

Slide gates shall contain a flush-bottom seal attached to the frame invert member. The seal shall extend into the gate frames and provide complete sealing for the entire width of the disc. J-bulb type seals shall be mounted inside of the gate frame and be secured with stainless steel flat head screws and UHMW poly covers. J-bulb seals shall have mitered and epoxy-sealed corners.

## **Stainless Steel Slide and Weir Gate Specifications**

### **Stem Guides**

Guides shall be constructed of stainless steel, bronze bushed, adjustable and spaced to provide an l/r ratio of 200 or less.

### **Manual Lifts**

Gates shall be provided with either a handwheel or gear operated with cast bronze drive nuts threaded to engage the operating stem. Gear operators shall have bearings to support the opening and closing thrusts. Handwheel operators shall have cast aluminum handwheels and bearing housings. Gear operators shall have cast iron housings with positive mechanical seals. Dual interconnected gear operators shall be provided for all gates where width is 5 ft. and larger and is double the gate height.

### **Stem Covers**

Operators shall be provided with clear butyrate stem covers with vent holes and rain caps. Travel shall be indicated on mylar scales designed for outside conditions and marked to properly indicate open and closed positions in 1" increments.

### **Identification**

All gates shall be provided with aluminum nameplates permanently fastened to gate and provided with manufacturer's information.

### **Shop Tests**

All gates shall be subjected to welding and assembly criteria as outlined in Northcoast Valve & Gate, Inc. "Quality Control Manual" and submitted with detailed shop drawings during review process.

### **Installation**

All gates shall be installed as detailed in manufacturer's installation guide.

## **Stainless Steel Slide and Weir Gate Specifications**

### **Start-Up Testing**

Contractor shall make all installations and provide for adjustments as necessary to place system in proper operating order. Contractor shall conduct field check in presence of owner or agent to demonstrate proper operation of product.

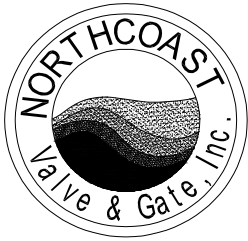

# STAINLESS STEEL SLIDE GATES SERIES SS-100

- \* WALL MOUNTED FRAMES
- \* SELF CONTAINED
- \* J-BULB SEALS
- \* FLUSH BOTTOM SEAL

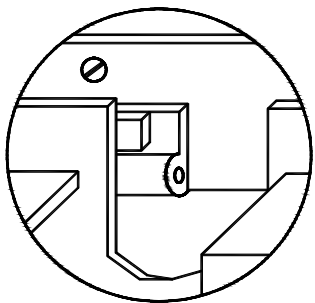

TOP SEAL DETAIL

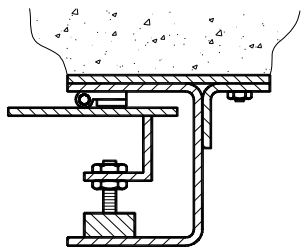
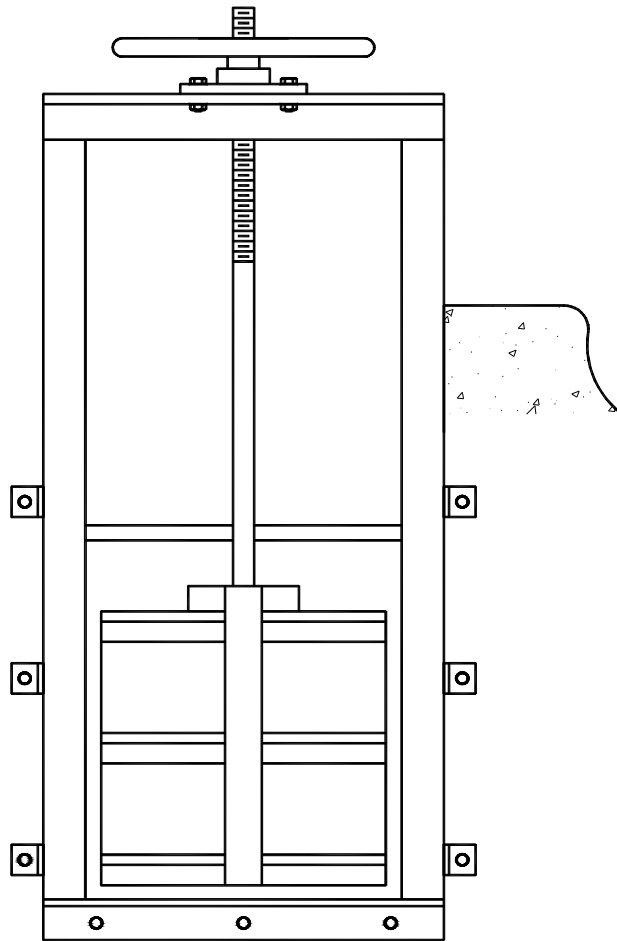

FRAME DETAIL

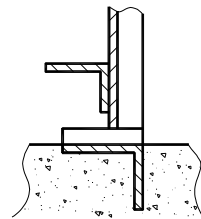

BOTTOM CLOSURE DETAIL



# STAINLESS STEEL SLIDE GATES SERIES SS-200

- \* EMBEDDED FRAMES
- \* SELF CONTAINED
- \* J-BULB SEALS
- \* FLUSH BOTTOM SEAL

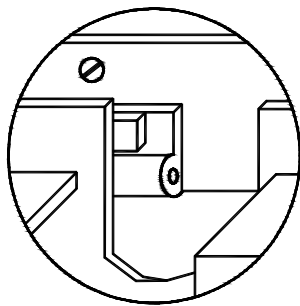
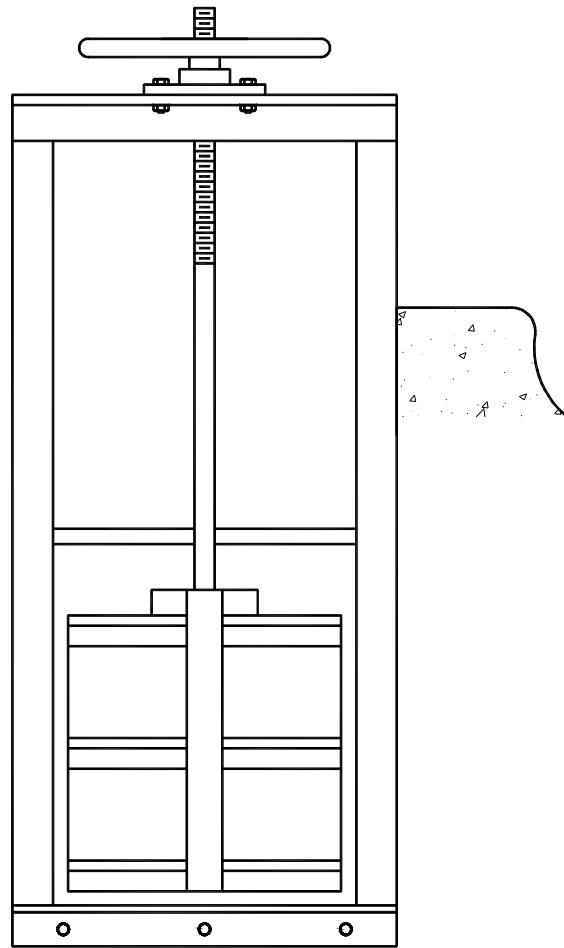

TOP SEAL DETAIL

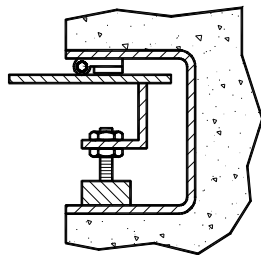

FRAME DETAIL

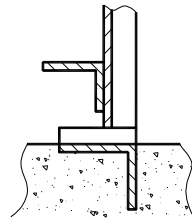

BOTTOM CLOSURE DETAIL



# STAINLESS STEEL SLIDE GATES SERIES SS-300

- \* WALL MOUNTED FRAMES
- \* NON-SELF CONTAINED
- \* J-BULB SEALS
- \* FLUSH BOTTOM SEAL

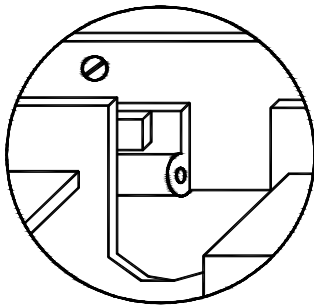

TOP SEAL DETAIL

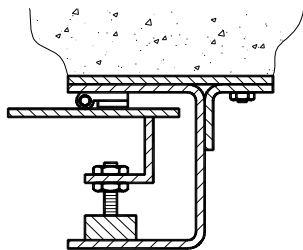
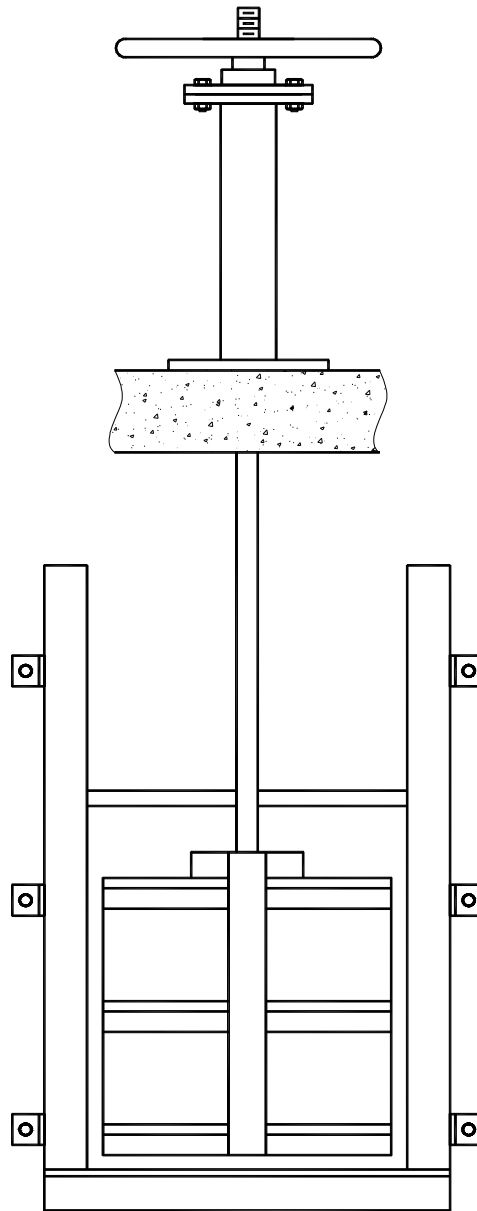

FRAME DETAIL

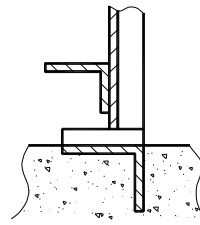

BOTTOM CLOSURE DETAIL



# STAINLESS STEEL WEIR GATES SERIES SS-401

- \* WALL MOUNTED FRAMES
- \* SELF CONTAINED
- \* J-BULB SEALS
- \* DOWNWARD OPENING
- \* DUAL INTERCONNECTED OPERATOR

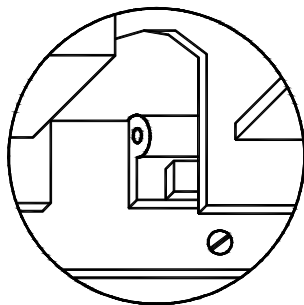
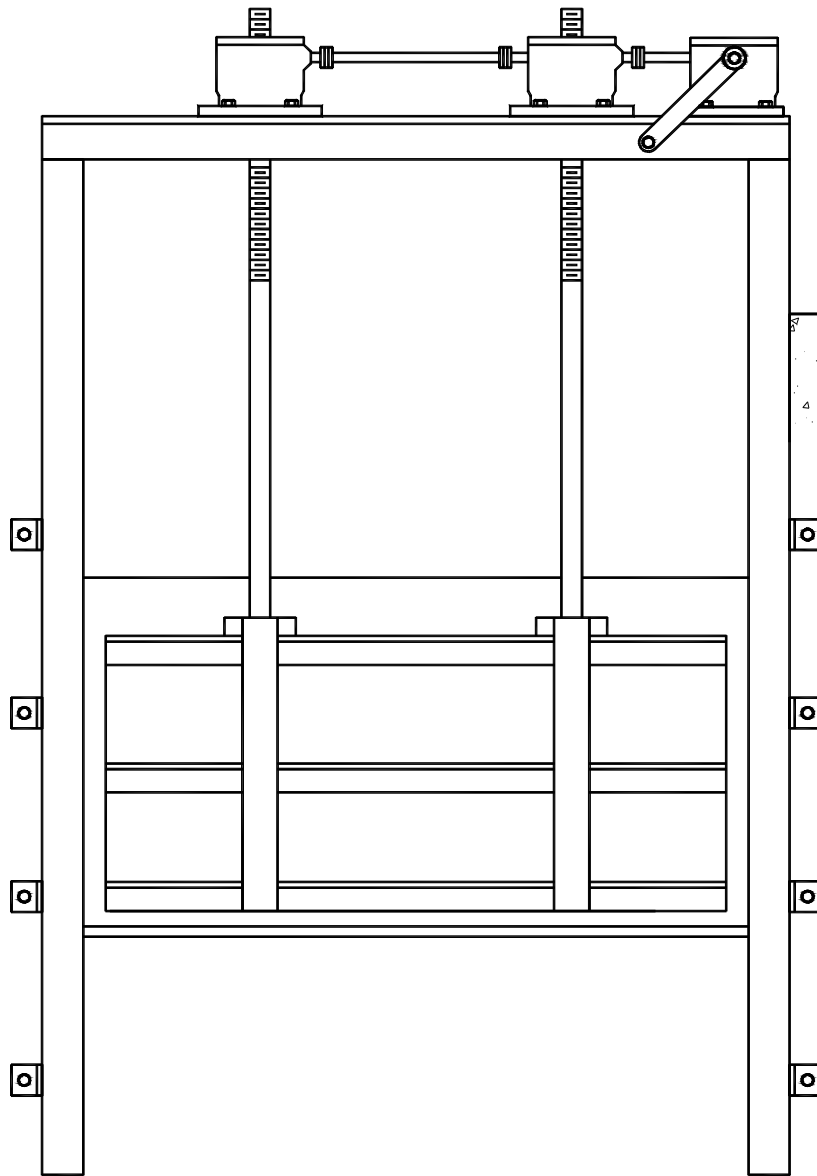

SILL SEAL DETAIL

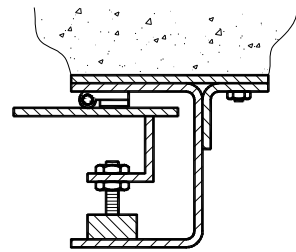

FRAME DETAIL